

NACA Technical Note 3808
Wind-Tunnel Calibration of a Combined
Pitot-Static Tube and Vane-Angularity
Indicator at Mach Numbers of 1.61 and
2.01

S083H(NC)



Military fighter, helicopter, business jet, and UAV examples
of SpaceAge Control air data products in use.

Document provided courtesy of

SpaceAge Control, Inc.

An ISO 9001/AS9000-Compliant Company

38850 20th Street East • Palmdale, CA 93550 USA

661-273-3000 • Fax: 661-273-4240 • email@spaceagecontrol.com



For other technical papers such as those listed below, visit:

<http://spaceagecontrol.com/litroom.htm#B>

- *Airdata Measurement and Calibration* (TM 104316)
 - air data measurement methods; includes references and bibliography
- *Measurement of Static Pressure on Aircraft* (Report 1364)
 - detailed information on how to mount air data booms
- *Airdata Calibration of a High-Performance Aircraft for Measuring Atmospheric Wind Profiles* (TM 101714)
 - how to maximize air data accuracy from air data booms.
- *Investigation of the Fuselage Interference on a Pitot-Static Tube Extending Forward From the Nose of the Fuselage* (TN1496)
- *Accuracy of Airspeed Measurements and Flight Calibration Procedures* (Report 919)
- *Wind-Tunnel Calibration of a Combined Pitot-Static Tube and Vane-Type Flow-Angularity Indicator at Mach Numbers of 1.61 and 2.01* (TN 3808)
- *The Measurement of Air Speed in Airplanes* (TN 616)
- *Summary of Methods of Measuring Angle of Attack on Aircraft* (TN 4351)
- *Measurement of Aircraft Airspeed and Altitude* (RP 1046)
- *Position Error Calibration of a Pressure Survey Aircraft Using a Trailing Cone* (TN-313)

For information air data products that measure total pressure, static pressure, outside air temperature (OAT), total air temperature (TAT), angle of attack (AOA, alpha), and angle of sideslip (AOS, beta), contact us:



38850 20th Street East ♦ Palmdale, CA 93550 USA
www.spaceagecontrol.com ♦ email@spaceagecontrol.com
661-273-3000 ♦ 661-273-4240 (fax)

10162
NACA TN 3808 NL ACAN

TECH LIBRARY KAFB, NM
0066768

NATIONAL ADVISORY COMMITTEE FOR AERONAUTICS

TECHNICAL NOTE 3808

WIND-TUNNEL CALIBRATION OF A COMBINED PITOT-STATIC TUBE
AND VANE-TYPE FLOW-ANGULARITY INDICATOR AT MACH
NUMBERS OF 1.61 AND 2.01

By Archibald R. Sinclair and William D. Mace

Langley Aeronautical Laboratory
Langley Field, Va.



Washington

October 1956

AFMDC
TECHNICAL LIBRARY
AFL 2811



TECHNICAL NOTE 3808

WIND-TUNNEL CALIBRATION OF A COMBINED PITOT-STATIC TUBE

AND VANE-TYPE FLOW-ANGULARITY INDICATOR AT MACH

NUMBERS OF 1.61 AND 2.01

By Archibald R. Sinclair and William D. Mace

SUMMARY

A limited calibration of a combined pitot-static tube and vane-type flow-angularity indicator has been made in the Langley 4- by 4-foot supersonic pressure tunnel at Mach numbers of 1.61 and 2.01. The results indicate that the instrument registers too high an angle of attack and gives an error of 0.7° at an angle of attack of 20° for a Mach number of 1.61 and an error of 1.6° at an angle of attack of 24° for a Mach number of 2.01. At zero angle of attack the flow field about the yaw vane was unsymmetrical and caused an error of 1.4° in yaw indication at zero angle of yaw for a Mach number of 2.01. The installation of a dummy vane pedestal to provide a more symmetrical flow field reduced this error to 0.25° . The probe gave static-pressure readings which were too low at angles of yaw.

INTRODUCTION

A combined pitot-static tube and vane-type flow-angularity indicator has been designed by the National Advisory Committee for Aeronautics for use on research aircraft. This instrument is designed to measure impact and static pressures by means of a pitot-static tube and to measure angles of attack and yaw by means of two free-floating vanes. The purpose of the present investigation in the Langley 4- by 4-foot supersonic pressure tunnel was primarily to obtain an aerodynamic calibration of the angle-of-attack vane at supersonic speeds, since this calibration was required in order to evaluate the drag characteristics of supersonic research aircraft. Tests were made at Mach numbers of 1.61 and 2.01 and at pressure altitudes of 30,000 feet and 60,000 feet. A limited amount of calibration data were also obtained for the angle-of-yaw vane. The effect of yaw on the indicated static pressure is also presented. The effectiveness of a dummy vane pedestal in producing a more symmetrical flow field about the angle-of-yaw vane was also investigated.

SYMBOLS

M	stream Mach number
p_{∞}	free-stream static pressure
p_1	free-stream static pressure as indicated by instrument
q_c	stream total pressure minus stream static pressure
α	angle of attack, deg
ψ	angle of yaw, deg

APPARATUS AND TESTS

The instrument which was calibrated in this investigation (fig. 1) consisted of a pitot-static tube for indicating impact and static pressures and free-swiveling vanes for indicating angles of attack and yaw. This instrument is similar to the one previously calibrated in the Langley 8-foot transonic tunnel. (See ref. 1.) The major differences are in the shape of the pitot tube and in the dimensions of the vanes. In the present instrument the vanes have no stops and can rotate a full 360° .

Details of the pitot-static component of the instrument are shown in figure 2. There are two identical groups of static orifices, forward and rearward, and each group is brought out independently. There are a larger number of orifices on the bottom of the tube than on the top in order to reduce the static-pressure error at positive angles of attack.

The angularity-indicating component consists of free-swiveling mass-balanced vanes located downstream of the pitot-static component on the enlarged part of the instrument, as shown in figure 1. For some tests, a dummy vane pedestal was mounted opposite the angle-of-attack vane pedestal as shown by the dashed outline.

When this system is used in flight, vane position is measured by means of a synchro-transmitter system connected to the vanes. For the calibration in the wind tunnel, this system could not be used directly because of variable and unknown deflections of the probe and the support system under aerodynamic loading. In order to eliminate the effect of these deflections, an optical system used in conjunction with a small mirror mounted flush in one of the vanes was used to measure the angle of the vane relative to the tunnel center line. The vane error could

thus be measured directly, independently of any deflections, and with a high degree of accuracy. For the calibration of angle of yaw with variation of angle of attack at $M = 2.01$, the data from the synchro transmitter were faired through data points obtained optically. The maximum error in the optically measured angles is believed to be less than 0.1° .

For the tunnel tests, the instrument was mounted on an adapter as shown in figure 3. This adapter, in conjunction with the regular model support sting, was designed to maintain the angle-of-attack vane axis at very nearly the same point near the tunnel center line when the probe angle was changed in the horizontal plane. The adapter-sting combination was fitted with several joints permitting a 360° rotation of the probe; thereby, either the angle-of-attack vane or the yaw vane could be placed in a horizontal plane containing the tunnel axis.

Tests were made at stream static pressures corresponding to altitudes of 30,000 feet and 60,000 feet at a Mach number of 1.61 and to an altitude of 60,000 feet at a Mach number of 2.01.

At $M = 1.61$, tests were made with the probe fixed at $\alpha = 0$ to check the repeatability of different vanes. For this purpose, tests were made with two different vanes chosen at random and with the vane in which the mirror was mounted. It was necessary to use the servo-transmitter system to read the vane position; but, since the probe was not moved, it can be assumed that the probe deflection was the same in all three tests. No significant differences were found in the trail angles of the three different vanes.

For both the angle-of-attack and the angle-of-yaw tests, repeat tests were made with the probe rotated 180° to eliminate the effect of any tunnel flow angularity.

At each Mach number, a transverse survey of the test section was made by moving the probe across the test section at a fixed angle of attack of 5° while the angular position of the mirror-fitted vane was measured optically. The variation in flow angularity was found to be less than 0.10. The maximum variation in $\frac{P_i - P_\infty}{q_c}$ was 0.003 at $M = 1.61$ and 0.001 at $M = 2.01$.

Probe static pressures were measured, but for the angle-of-attack tests the results showed only random scatter with no significant trends. The explanation of this scatter is not entirely known, but it is probably partly a result of the pitot-static part of the probe moving in a large arc across the forward part of the test section where there may have been flow variations in regions not covered by the transverse survey. These angle-of-attack pressure data are, consequently, not presented. Variation of probe static pressure with yaw, however, was of sufficient magnitude to show a systematic trend and is presented for $M = 2.0$.

RESULTS AND DISCUSSION

The results of the angle-of-attack correction at zero angle of yaw are shown in figure 4, where the angle-of-attack correction (the true value of α minus the measured value of α) is plotted against angle of attack. These results show that at zero angle of attack the probe indicates correctly but, as α increases, the probe indicates too high an angle. This error reaches a maximum of about 0.7° at $\alpha = 20^\circ$ for $M = 1.61$ and 1.6° at $\alpha = 24^\circ$ for $M = 2.01$. This error is probably a result of upwash around the inclined cylindrical part of the probe. The effect of altitude is within the accuracy of the measurements except possibly at $\alpha = 20^\circ$, where the error is about 0.1° less at 60,000 feet than it is at 30,000 feet for $M = 1.61$.

The variation of angle-of-yaw correction (the true value of ψ minus the measured value of ψ) with angle of yaw for $M = 2.01$ is shown in figure 5. At zero angle of attack (fig. 5(a)) the correction at zero angle of yaw was 1.4° . This large error probably results from the unsymmetrical effects of the strong detached shock ahead of the angle-of-attack vane pedestal. In an effort to make the flow field about the angle-of-yaw vane more symmetrical, a dummy pedestal (see fig. 1) was installed opposite the angle-of-attack vane pedestal. As shown by the dashed curve in figure 5(a), the resulting error curve is more nearly symmetrical. The correction at zero angle of yaw was reduced from 1.4° to 0.25° . Similar yaw data for an angle of attack of 9.8° are shown in figure 5(b). For this angle of attack the yaw vane was apparently out of the influence of the unsymmetrical flow field, since the yaw correction is essentially zero both with and without the dummy pedestal. Only limited optical data could be obtained with this configuration because of the geometry of the installation.

The variation of angle-of-yaw correction with angle of attack at zero angle of yaw and a Mach number of 2.01 is shown in figure 6. Optical measurements were obtained for only two angles of attack, 0° and 9.8° , as indicated by the symbols. The curves through these points were obtained by adjusting the data obtained from the synchro-transmitter system so that the curves passed through the points obtained by optical measurement. The method used in adjusting these data was based on the assumption that the errors in the synchro-transmitter data were a result of an angular deflection of the probe; probe deflection was assumed to be a linear function of angle of attack. Some error probably results from this assumption, but the trends shown are probably correct. From these results it appears that the unsymmetrical-flow effects on the angle-of-yaw vane largely disappear at angles of attack above about 7° .

The variation of measured probe static pressure with angle of yaw is shown in figure 7. The probe static pressure showed a rapid drop with an increase in angle of yaw, as would be expected with a probe

having orifices on only the top and the bottom of the tube. The indicated static pressure is about 5 percent too low in terms of q_c at $\psi = 20^\circ$.

CONCLUSIONS

A wind-tunnel calibration of a combined pitot-static tube and vane-type flow-angularity indicator at Mach numbers of 1.61 and 2.01 has led to the following conclusions:

1. At zero angle of yaw, the instrument registers too high an angle of attack, except at an angle of attack of zero. The error was a function of Mach number and increased with angle of attack to a maximum of about 0.7° at an angle of attack of 20° for a Mach number of 1.61 and 1.6° at an angle of attack of 24° for a Mach number of 2.01.

2. The unsymmetrical flow field from the angle-of-attack vane pedestal caused large errors in the yaw-vane indications at an angle of attack of zero. This error reached a maximum of 1.4° at zero angle of yaw at a Mach number of 2.01. Installation of a dummy pedestal to give a more symmetrical flow field reduced this error to 0.25° . The unsymmetrical flow effects largely disappeared at angles of attack greater than about 7° .

3. The static-pressure tube with orifices on the top and bottom gave readings which were too low at angles of yaw.

Langley Aeronautical Laboratory,
National Advisory Committee for Aeronautics,
Langley Field, Va., June 14, 1956.

REFERENCE

1. Pearson, Albin O., and Brown, Harold A.: Calibration of a Combined Pitot-Static Tube and Vane-Type Flow Angularity Indicator at Transonic Speeds and at Large Angles of Attack or Yaw. NACA RM L52F24, 1952.

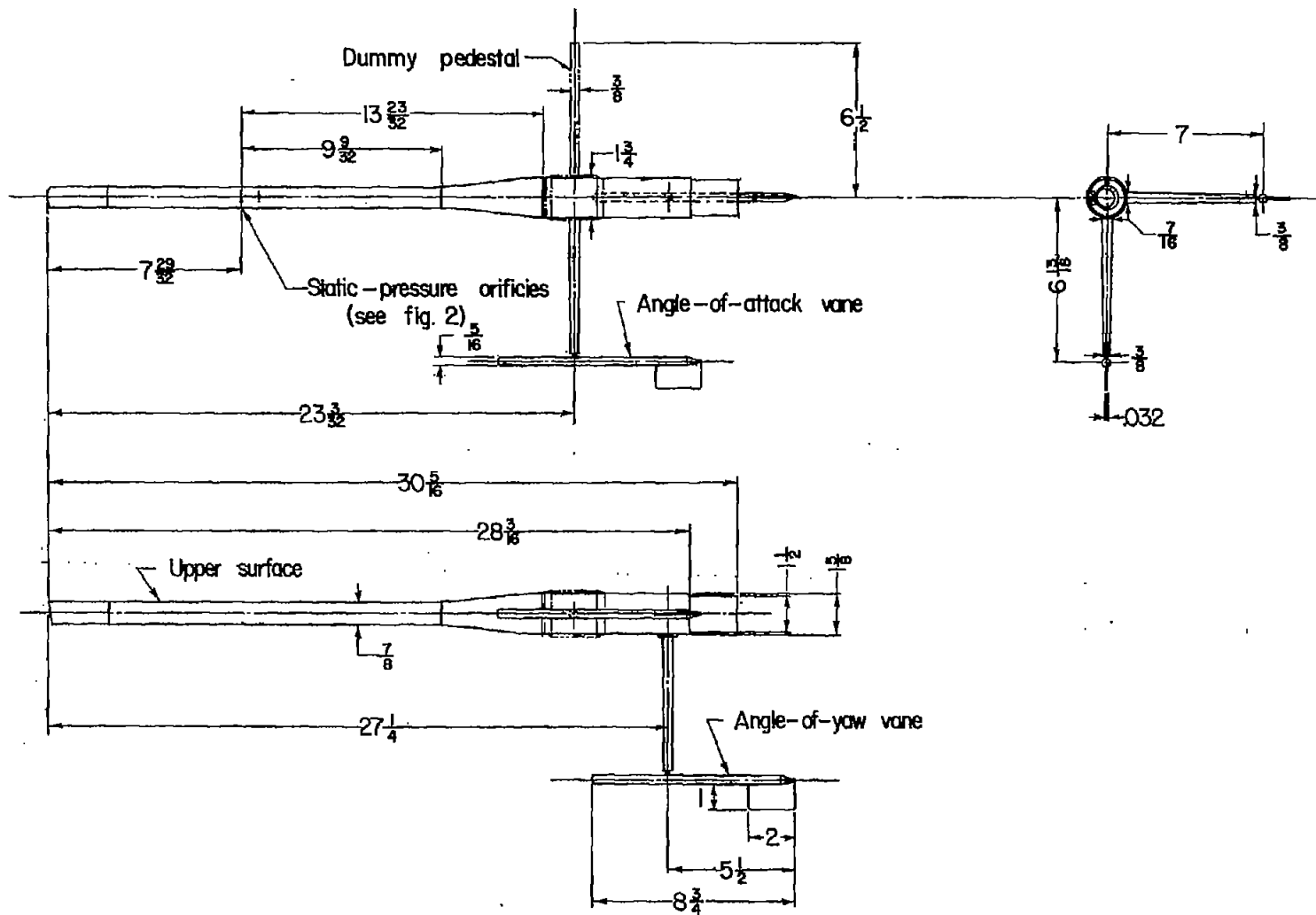

Figure 1.- Details of combined pitot-static tube and vane-type flow angularity indicator. All dimensions are in inches.

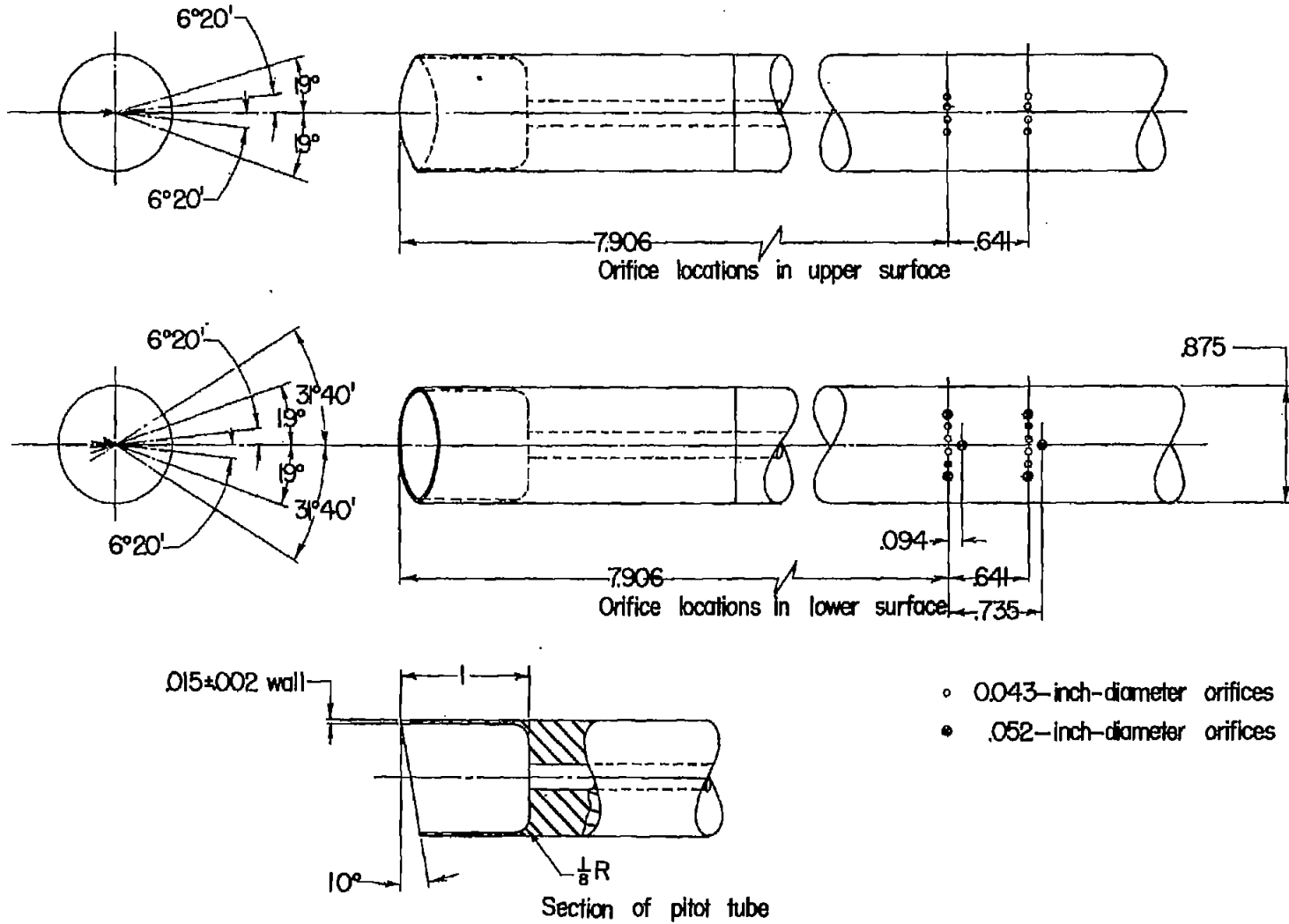

Figure 2.- Details of pitot-static tube. All linear dimensions are in inches.

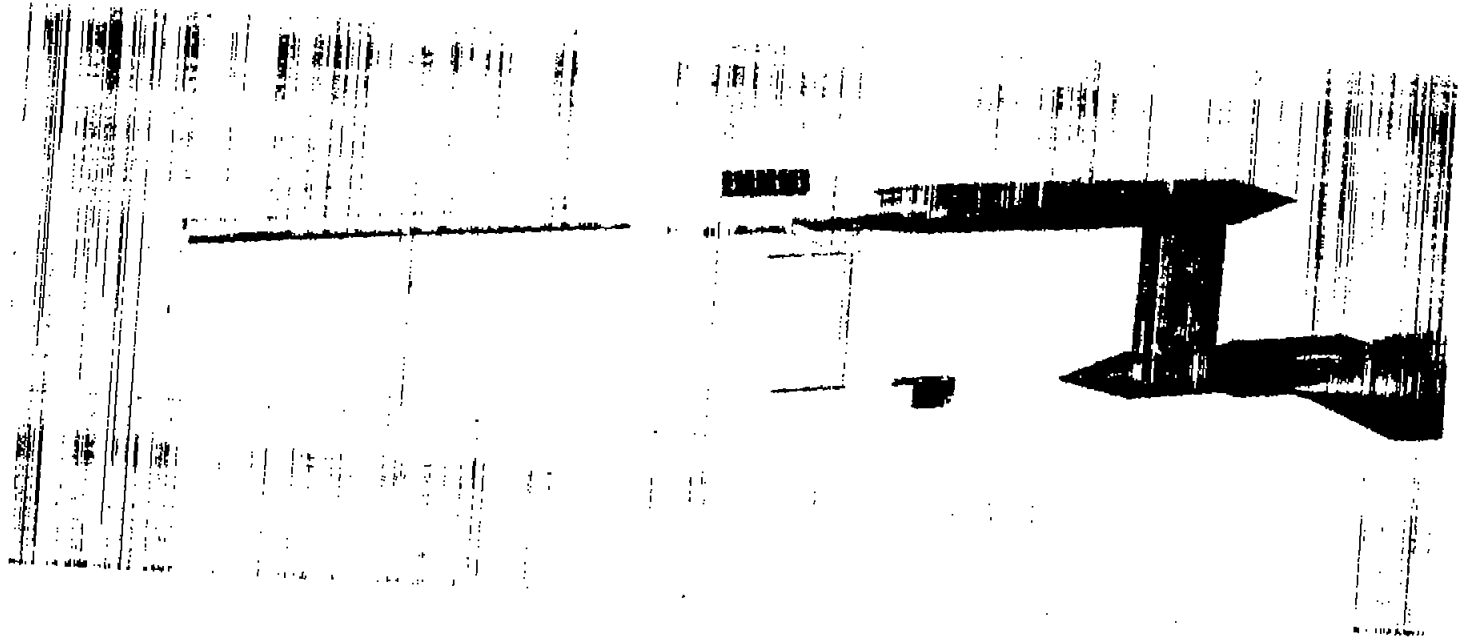

Figure 3.- Combined pitot-static tube and vane-type flow-angularity indicator mounted on tunnel adapter.

L-90436.1

NACA TN 3808

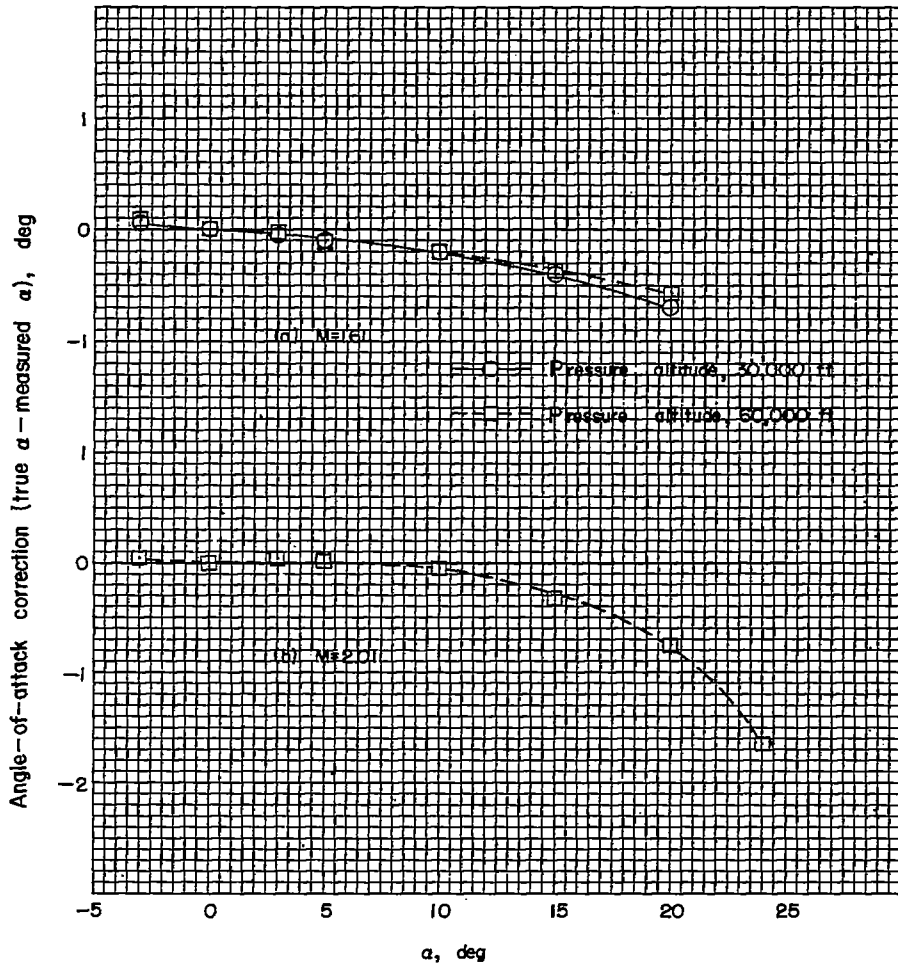

Figure 4.- Variation of angle-of-attack correction with angle of attack.
 $\psi = 0^\circ$.

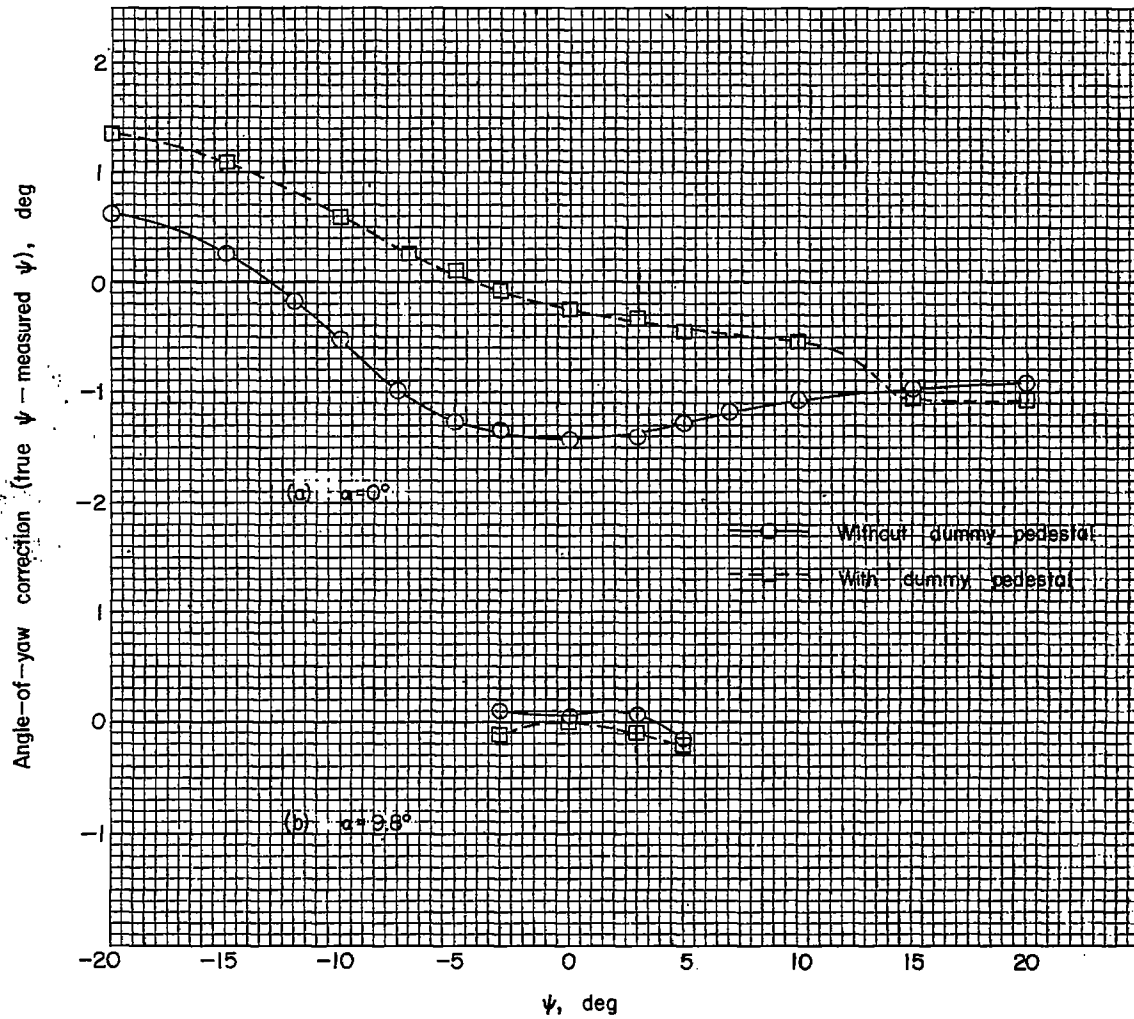

Figure 5.- Variation of angle-of-yaw correction with angle of yaw.
 $M = 2.01$; pressure altitude, 60,000 feet.

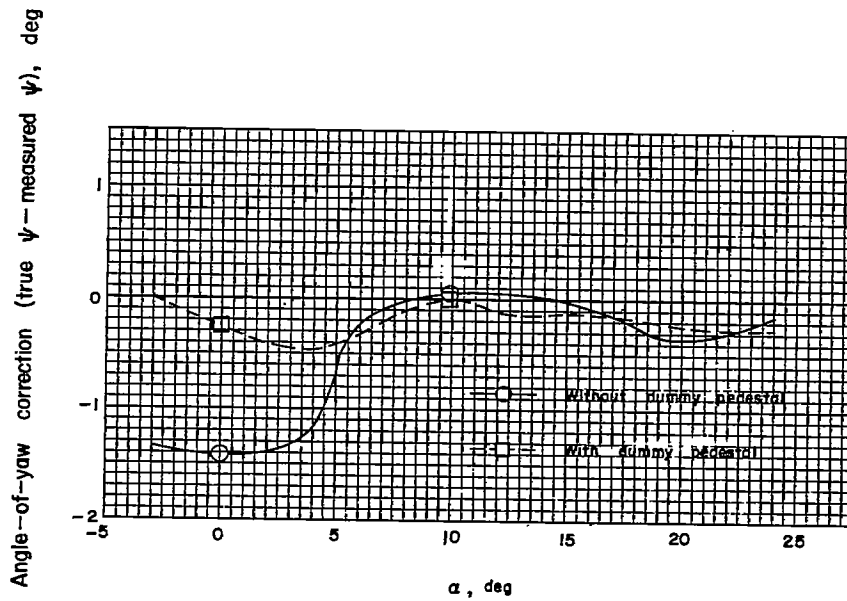

Figure 6.- Variation of angle-of-yaw correction with angle of attack.
 $M = 2.01$; pressure altitude, 60,000 feet; $\psi = 0^\circ$.

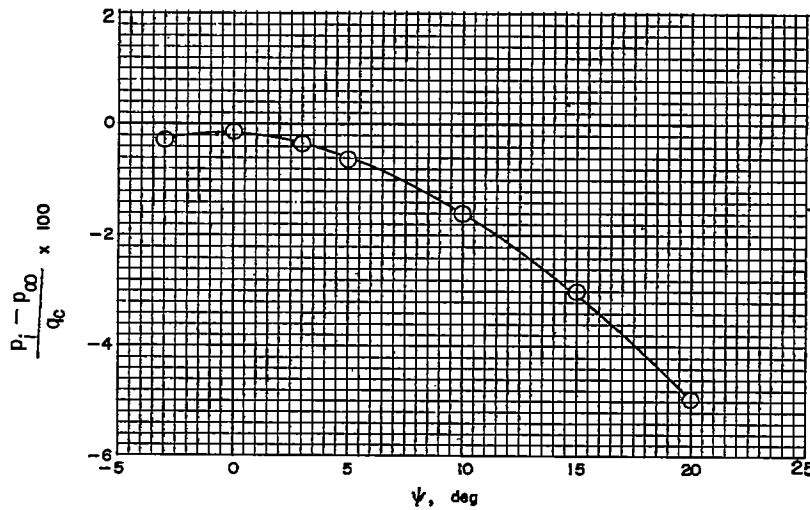

Figure 7.- Variation of measured probe static pressure with angle of yaw.
 $M = 2.01$; pressure altitude, 60,000 feet; $\alpha = 0^\circ$. Pressures obtained from forward orifices.