

This drawing contains design and other information which is the property of SpaceAge Control, Inc. Except for rights expressly granted by contract to the United States Government, this drawing and data disclosed herein or herewith is not to be reproduced, used, or disclosed in whole or in part to anyone without the written permission of SpaceAge Control, Inc.

**NOTES: UNLESS OTHERWISE SPECIFIED**

- 1. FITTINGS: STAINLESS STEEL/STEEL
- 2. INTERNAL CABLE FEATURE: 0.094 OD, 7 x 7 SST
- 3. PULL TEST: 220 LBS MIN FOR 5 MINUTES (PRESSURE TUBE ASSY ONLY)
- 4. SAFETY WIRE HOLE LOCATIONS
- 5. EPOXY
- 6. USER REPLACEABLE SKIDS SECURED WITH SPRING PINS AND SAFETY WIRE
- 7. HARDWARE NOT SHIPPED WITH CONE, USER SUPPLIED AND INSTALLED
- 8. RECOMMENDED TORQUE ON USER-SUPPLIED HARDWARE: 35-40 IN-LBS MAX
- 9. MASS: 5.73 LB (2.6 KG) MAX (FOR ITEMS IN SECTION D-D VIEW ONLY NOT INCLUDING ITEMS IN NOTE 7 )

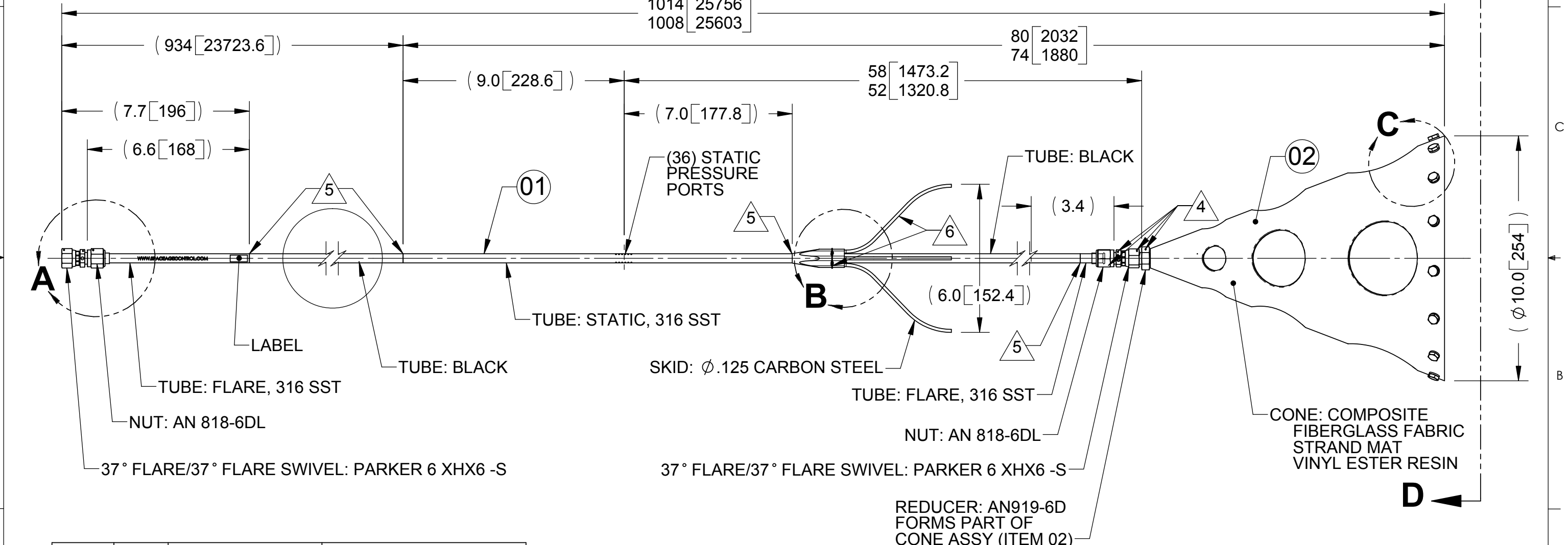

ITEM	QTY	PART NUMBER	DESCRIPTION
01	1	301449	PRESSURE TUBE ASSY
02	2	301419	CONE ASSY
03	8	301416	SKID
04	12	301413	SPRING PIN
05	1	301417	WIRE: SAFETY, MS20995
06	1	301235	SHIPPING BOX

1	100106	TRAILING CONE		
QTY REQD	CAGE CODE	PART OR IDENTIFYING NO.	NOMENCLATURE OR DESCRIPTION	MATERIAL SPECIFICATION
PARTS LIST				
UNLESS OTHERWISE SPECIFIED DIMENSIONS ARE IN INCHES TOLERANCES ARE:		PROJECT 167		
DECIMALS	ANGLES	APPROVALS		
X.X ± 0.03	X° ± 30'	DATE		
X.XX ± 0.01		DRAWN <b>B.P.</b>		
X.XXX ± 0.005		CHECKED		
DO NOT SCALE DRAWING		ENG		
MATERIAL	--	MFG		
FINISH	--	SIZE <b>B</b> CAGE CODE <b>34851</b> DWG. NO. <b>100106</b> REV. <b>-</b>		
NEXT ASSY	USED ON	SCALE <b>1:4</b> CAD FILE: SHEET <b>1</b> OF <b>4</b>		
APPLICATION		CAD GENERATED DRAWING. DO NOT MANUALLY UPDATE		

This drawing contains design and other information which is the property of SpaceAge Control, Inc. Except for rights expressly granted by contract to the United States Government, this drawing and data disclosed herein or herewith is not to be reproduced, used, or disclosed in whole or in part to anyone without the written permission of SpaceAge Control, Inc.

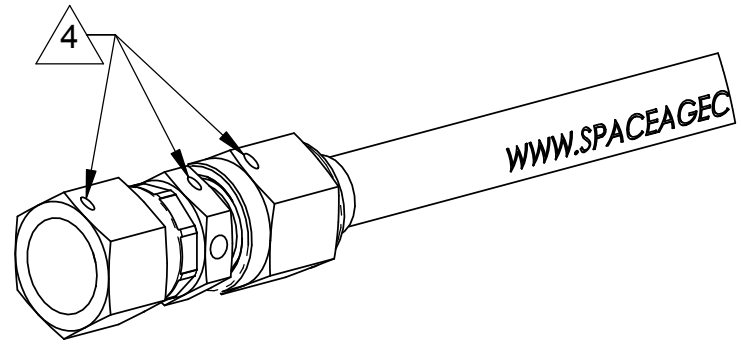

**DETAIL A  
SCALE 1 : 1**

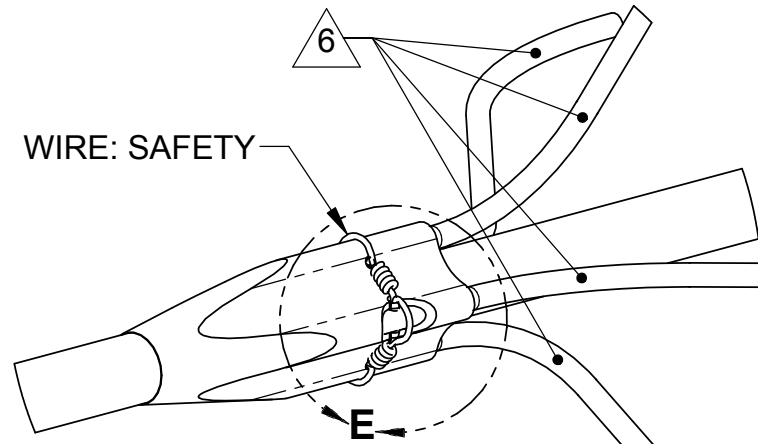

**DETAIL B  
SCALE 1 : 1**

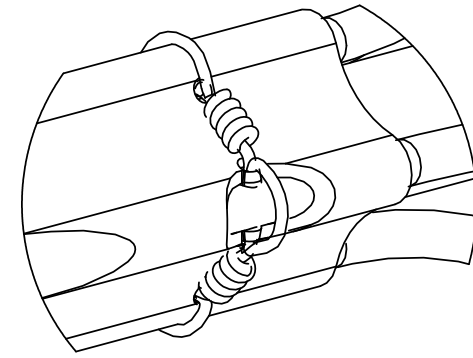

**DETAIL E  
SCALE 2 : 1**

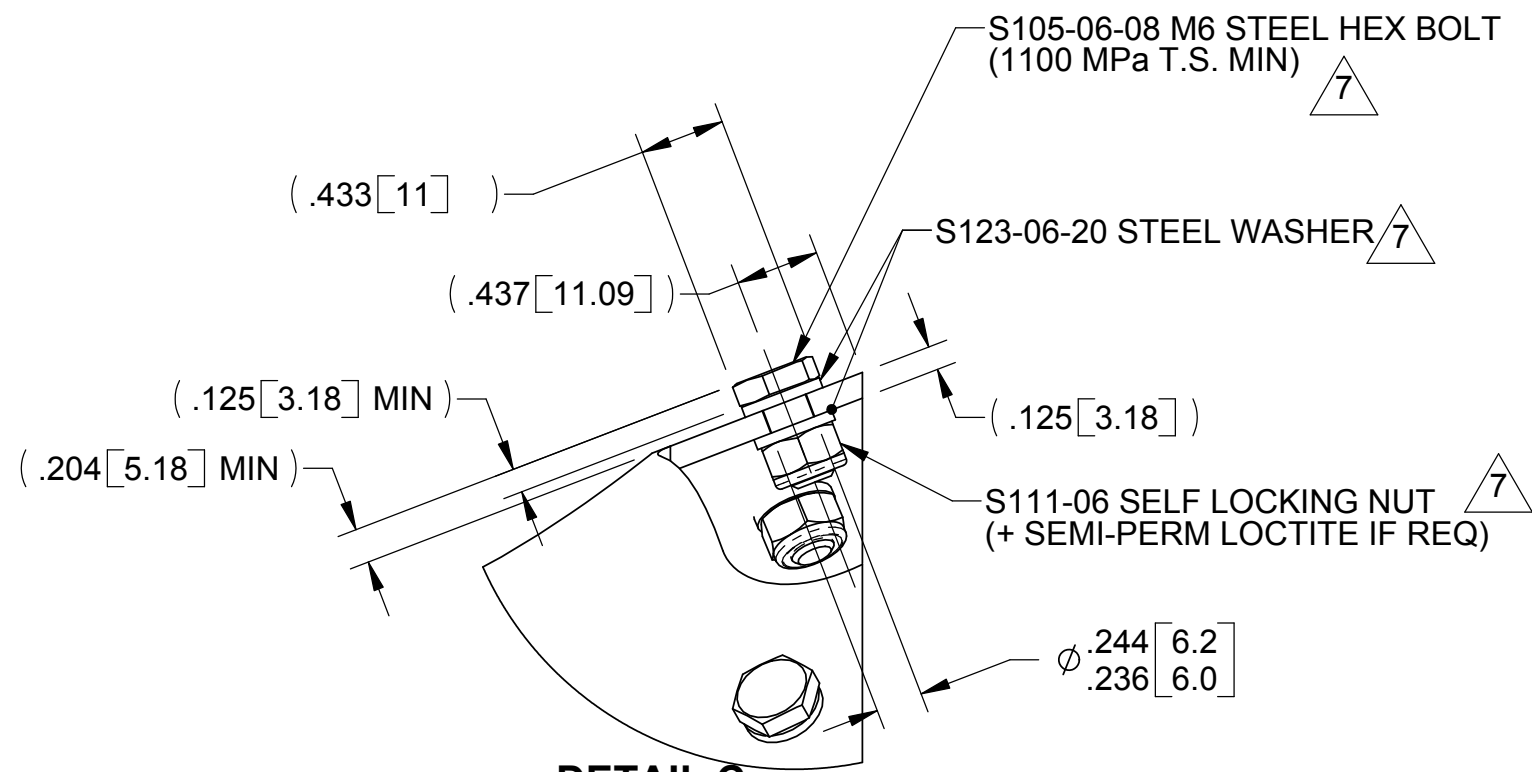

**DETAIL C  
SCALE 1 : 1  
(15 PLS)**

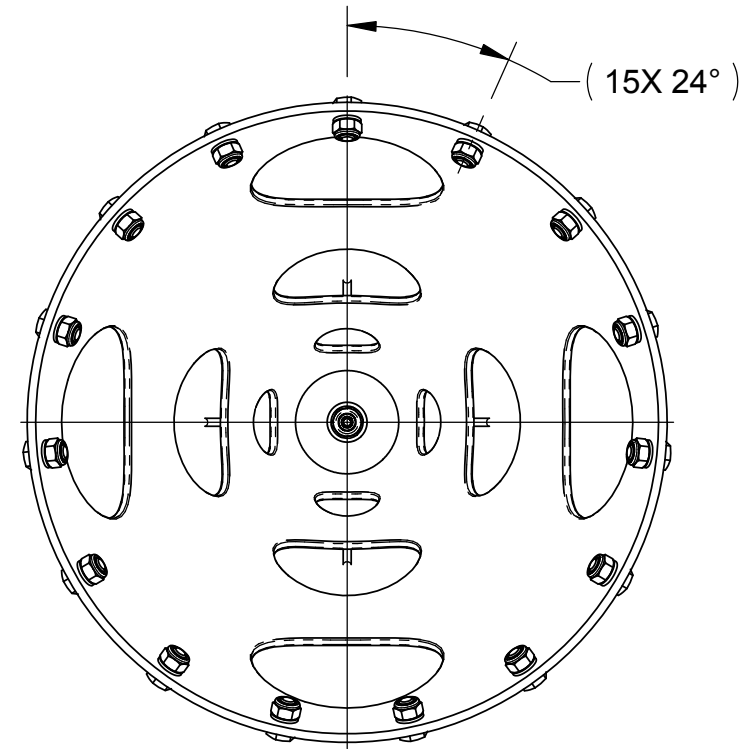

**VIEW D-D  
SCALE 1 : 3**

SIZE <b>B</b>	CAGE CODE <b>34851</b>	DWG. NO. <b>100106</b>	REV. -
SCALE 1:4	CAD FILE:	SHEET 2	OF 4

This drawing contains design and other information which is the property of SpaceAge Control, Inc. Except for rights expressly granted by contract to the United States Government, this drawing and data disclosed herein or herewith is not to be reproduced, used, or disclosed in whole or in part to anyone without the written permission of SpaceAge Control, Inc.

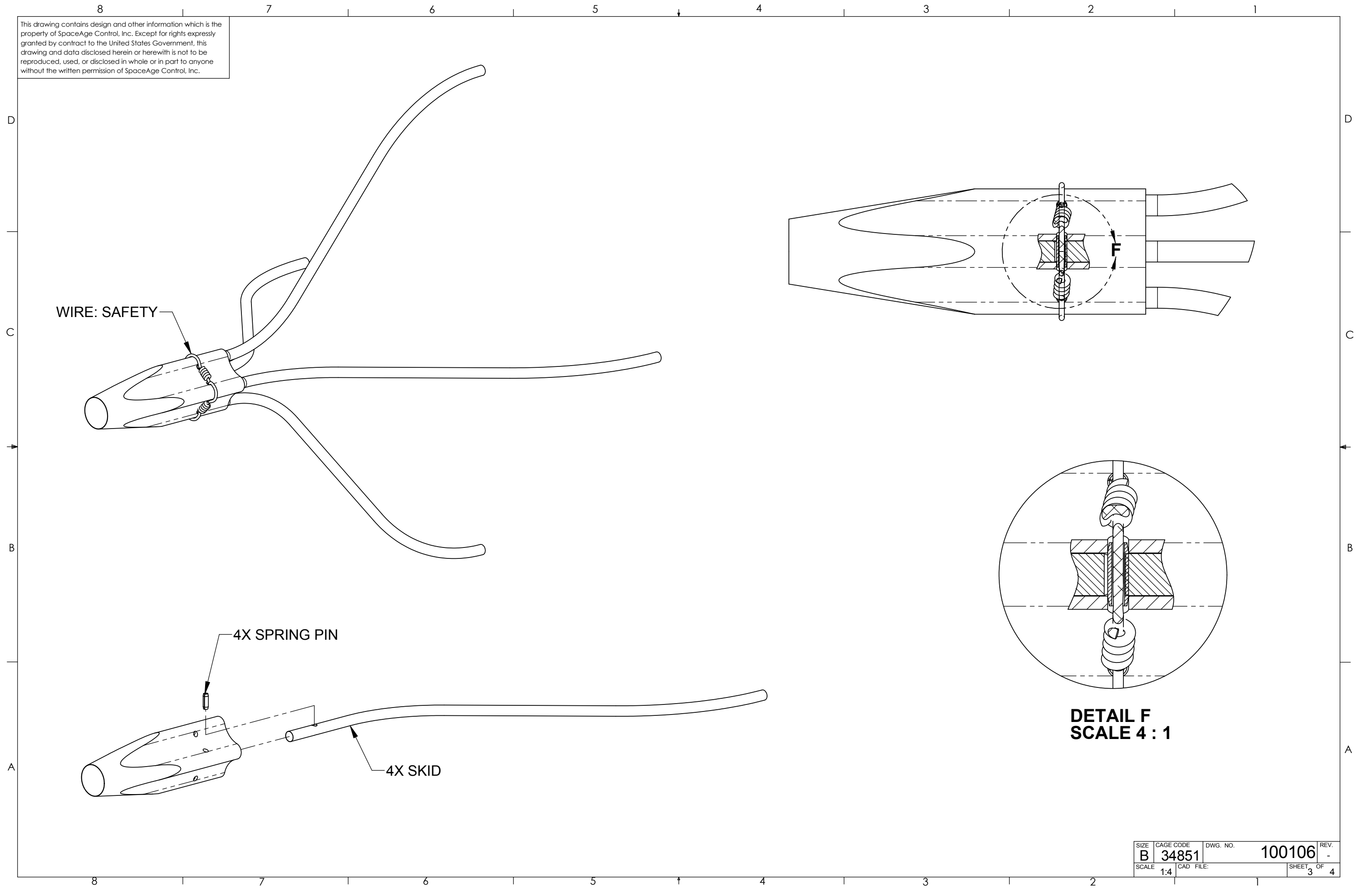

SIZE	CAGE CODE	DWG. NO.	REV.
B	34851	100106	-
SCALE	CAD FILE:	SHEET	OF
1:4		3	4

This drawing contains design and other information which is the property of SpaceAge Control, Inc. Except for rights expressly granted by contract to the United States Government, this drawing and data disclosed herein or herewith is not to be reproduced, used, or disclosed in whole or in part to anyone without the written permission of SpaceAge Control, Inc.

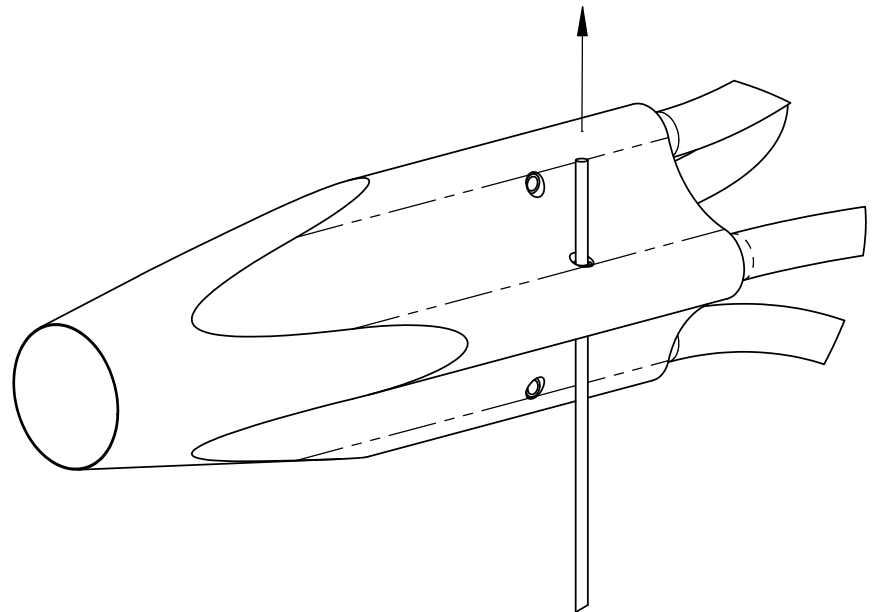

FEED SAFETY WIRE THRU HOLE IN SPRING PIN

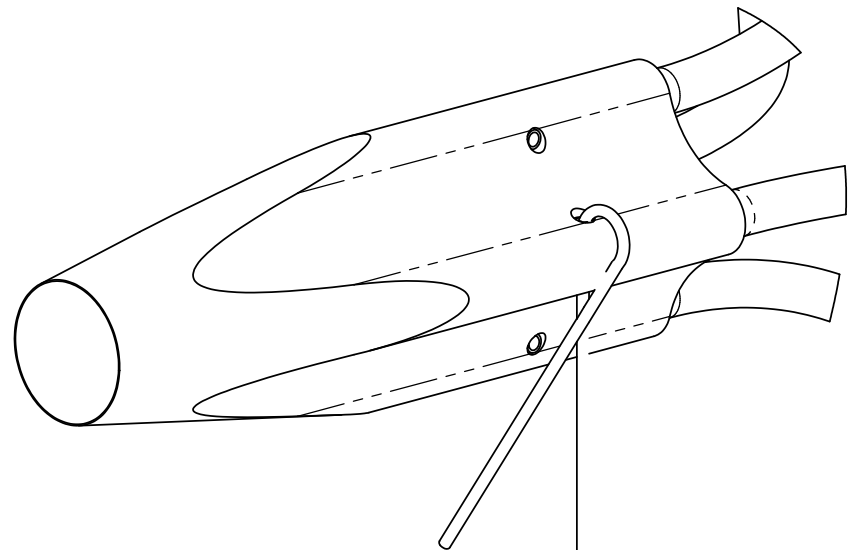

LOOP WIRE OVER EXTERIOR PROFILE

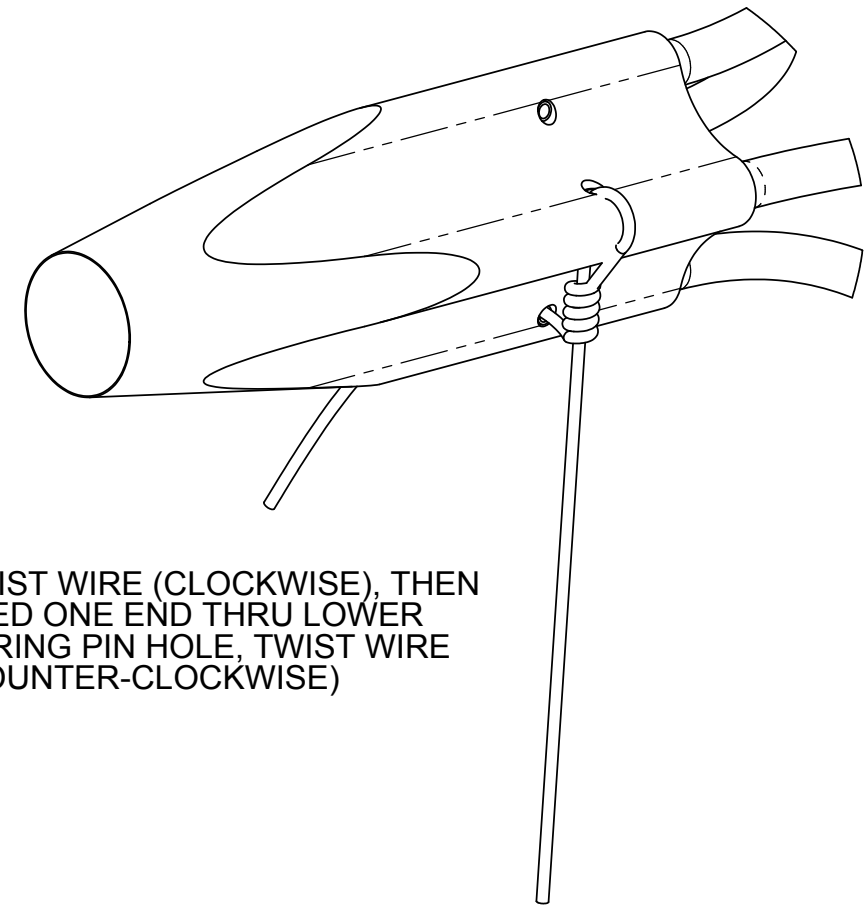

TWIST WIRE (CLOCKWISE), THEN FEED ONE END THRU LOWER SPRING PIN HOLE, TWIST WIRE (COUNTER-CLOCKWISE)

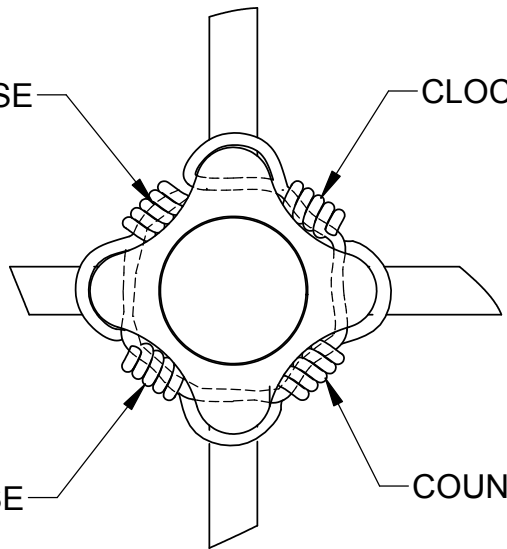

COUNTER-CLOCKWISE

CLOCKWISE

CLOCKWISE

COUNTER-CLOCKWISE

SIZE <b>B</b>	CAGE CODE <b>34851</b>	DWG. NO. <b>100106</b>	REV. -
SCALE 1:4	CAD FILE:	SHEET 4	OF 4